

Section AF - AF

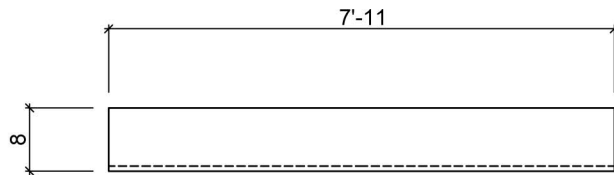

1 - a17 L8X6X5/8 - A36

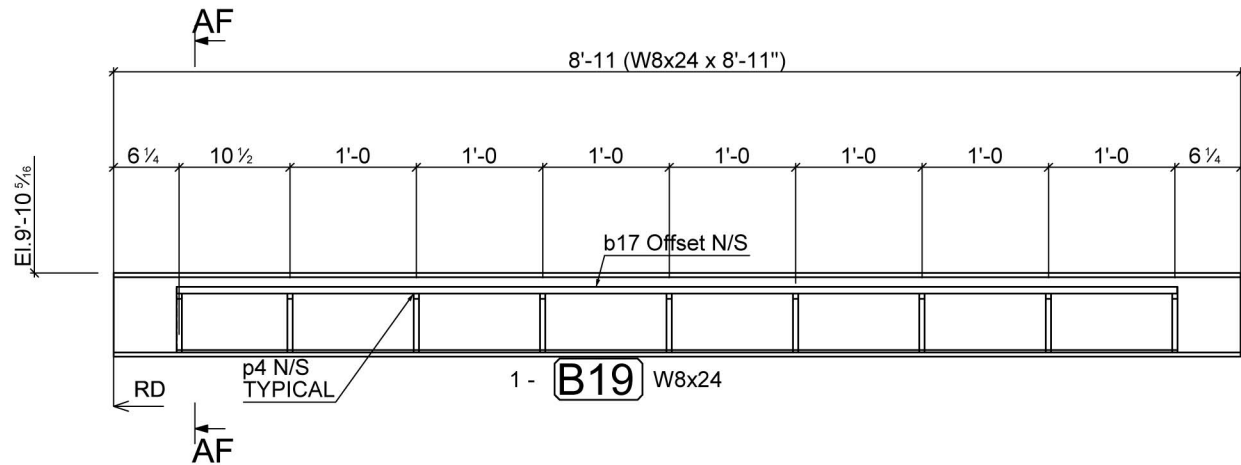
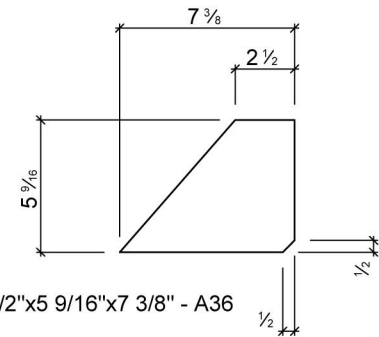

9 - p4 PL 1/2"x5 9/16"x7 3/8" - A36

Mark	Quantity	Description	Length	Grade	Part weight	Total weight
B19	1					
B19	1	W8x24	8'-11"	A992	214.00	214.00
b17	1	L8X6X5/8	7'-11"	A36	225.63	225.63
p4	9	PL 1/2"x5 9/16"x7 3/8"	7 3/8"	A36	3.89	35.00
	11				474.63	474.63
	11					474.63

Quantity	Description	Length
----------	-------------	--------

REV.	Date	BY	Description
A	1/24/2018	BV	FOR APPROVAL
B	3/5/2018		FIELD

Project :			Drawing No. :	
Project No. :			Misc-8	
Detailer :		Checker:	Client :	
Status : Not Set		Comment:		Phase :
		Holes : 13/16"Ø u/n	Date : 1/24/2018	
		Weld : E70XXELECT	B	
		Coating : None		